

REV.	DESCRIPTION/ECO NO.	DATE
	RELEASED	11/10/10

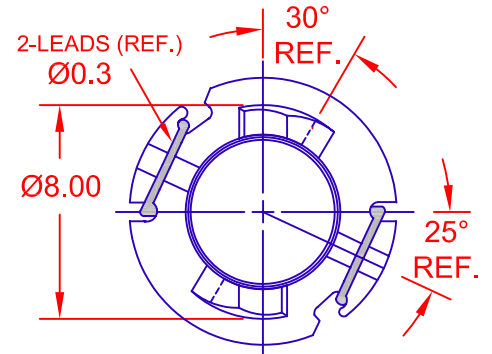

TOP VIEW

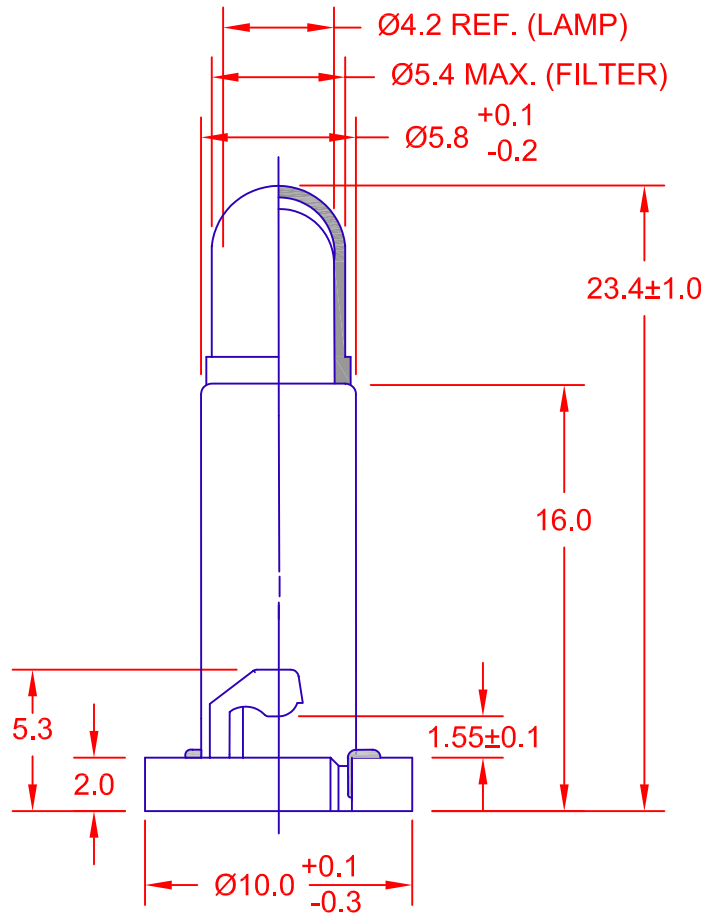
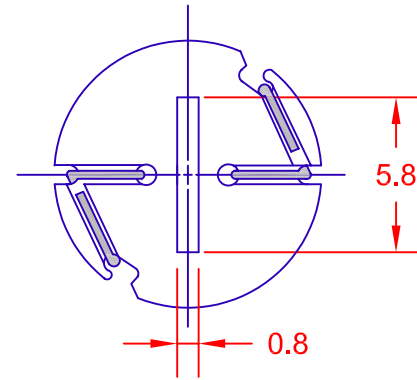

BOTTOM VIEW

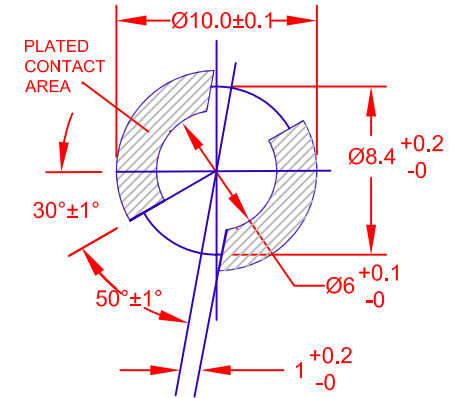

PC BOARD PUNCH PATTERN  
(NO TREATMENT, SUCH AS APPLICATION OF FLUX, SHALL BE DONE.)

<b>LAMP NUMBER: DW07</b>					
VOLTS RATED	AMPS ± 10%	*MSCP ± 25%	*LUMENS ± 25%	AVERAGE LIFE HRS.	FILAMENT TYPE
14.0	.080	.300	3.77	15,000	C-2V

\*LAMP RATING ONLY WITHOUT BASE AND FILTER

<b>FILTER NUMBER: 39-04-4H</b>
COLOR GREEN

<b>BASE COLOR</b>
GRAY

**JKL PART NUMBER: DNW1-DW07/GRA/22MM/39-04-4H**

<p>THIRD ANGLE PROJECTION</p>	<p>METRIC</p> <p>DIMENSIONS ARE IN MILLIMETERS</p> <p>TOLERANCE UNLESS OTHERWISE SPECIFIED</p> <p>1 PL +/- 0.2</p> <p>2 PL +/- 0.20</p> <p>ANGLE +/- 0</p>	<p><b>JKL COMPONENTS CORPORATION</b></p>			
	<p>TITLE</p> <p>DNW1 EXTENDED NEO-WEDGE BASE WITH DW07 LAMP AND 39-04 FILTER</p>	<p>SIZE</p> <p><b>A</b></p>	<p>FSCM NO.</p> <p><b>55335</b></p>	<p>DRAWING NO.</p> <p>DNW1-DW07/GRA/22MM/39-04-4H</p>	<p>DATE</p> <p>11/10/10</p>
<p>DRAWN BY</p> <p>L. WENGSTROM</p>	<p>APPV'D BY</p> <p>L.R.</p>	<p>DATE</p> <p>11/10/10</p>	<p>SCALE</p> <p>NONE</p>	<p>RELEASED DATE</p> <p>11/10/10</p>	<p>REVISION DATE</p>
<p>- CAD DRAWING -</p> <p>MANUAL REVISIONS NOT PERMITTED</p>			<p>REV. NO.</p>	<p>SHEET</p> <p>1 OF 1</p>	