

REV.	DESCRIPTION/ECO NO.	DATE
	ENGR. RELEASE TO CAD & CANCEL P-9903-21	4/5/04

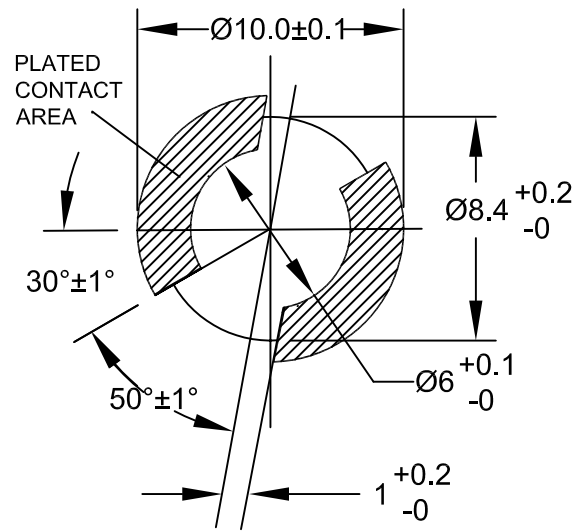

PC BOARD PUNCH PATTERN

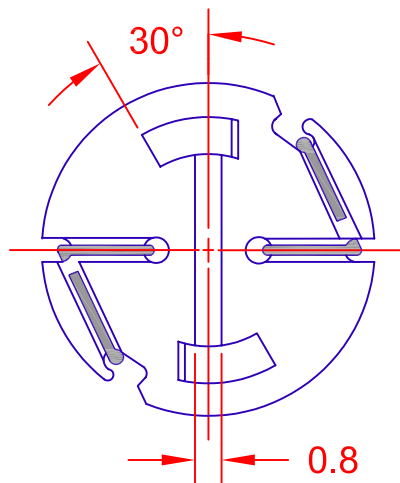
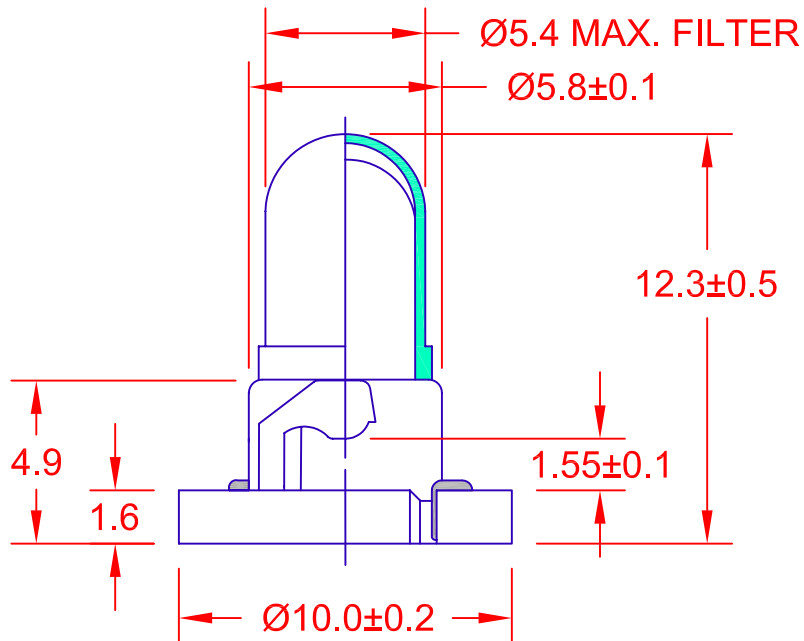

JKL PART NUMBER: DNW1-DW21/BLA12.0/39045J***

LAMP NUMBER: DW21**

VOLTS RATED	AMPS ± 10%	*MSCP ± 25%	*LUMENS ± 25%	AVERAGE LIFE HRS.	FILAMENT TYPE
14.0	.060	.200	2.51	5,000 D.C.	C-2V

* LAMP RATING ONLY WITHOUT BASE AND FILTER.

** LAMP GLASS LEAD (Pb) FREE.

*** LAMP AND BASE ASSEMBLY LEAD (Pb) FREE.

CONTACT JKL FOR LEAD (Pb) FREE LOT IDENTIFICATION.

FILTER NUMBER: 39-04-5J
COLOR COORDINATES (SPHERE):
x = .3471 ± .025
y = .4103 ± .025

BASE NUMBER: DNW1/BLA/5MM
BASE COLOR: BLACK

METRIC		DIMENSIONS ARE IN MILLIMETERS		JKL COMPONENTS CORPORATION			
 THIRD ANGLE PROJECTION	TOLERANCE UNLESS OTHERWISE SPECIFIED		TITLE T-1 1/4 NEO-WEDGE BASE WITH DW21 LAMP AND 39-04-5J				
	1 PL +/- 0.3 2 PL +/- 0.30 ANGLE +/- 0						
DRAWN BY L. WENGSTROM	APP'VD BY J.K.	DATE 3/14/05	SIZE A	FSCM NO. 55335	DRAWING NO. DNW1-DW21/BLA12.0/39045J		
- CAD DRAWING - MANUAL REVISIONS NOT PERMITTED			SCALE NONE	RELEASED DATE 3/14/05	REVISION DATE	REV. NO.	SHEET 1 OF 1