

REV.	DESCRIPTION/ECO NO.	DATE
	RELEASED AND CANCEL P-0206-20	7/15/02
A	CHANGE TO (Pb) FREE ASSEMBLY	1/18/05

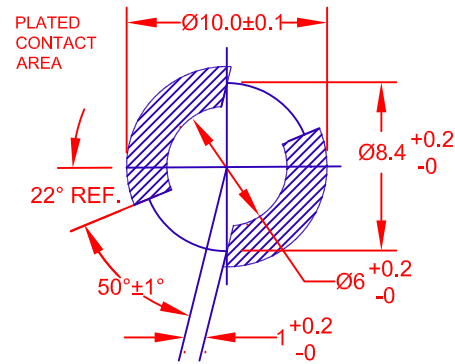

PC-BOARD THICKNESS: 1.6±0.1mm

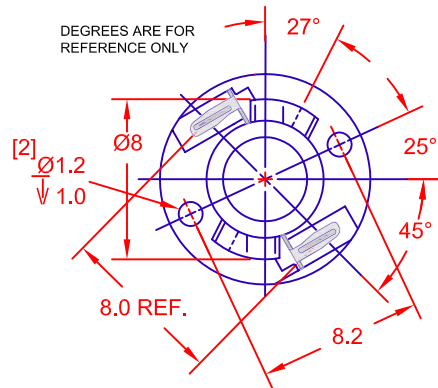
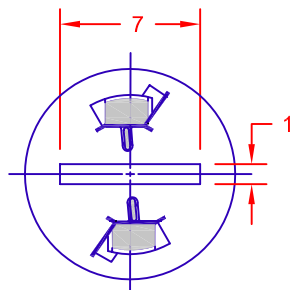
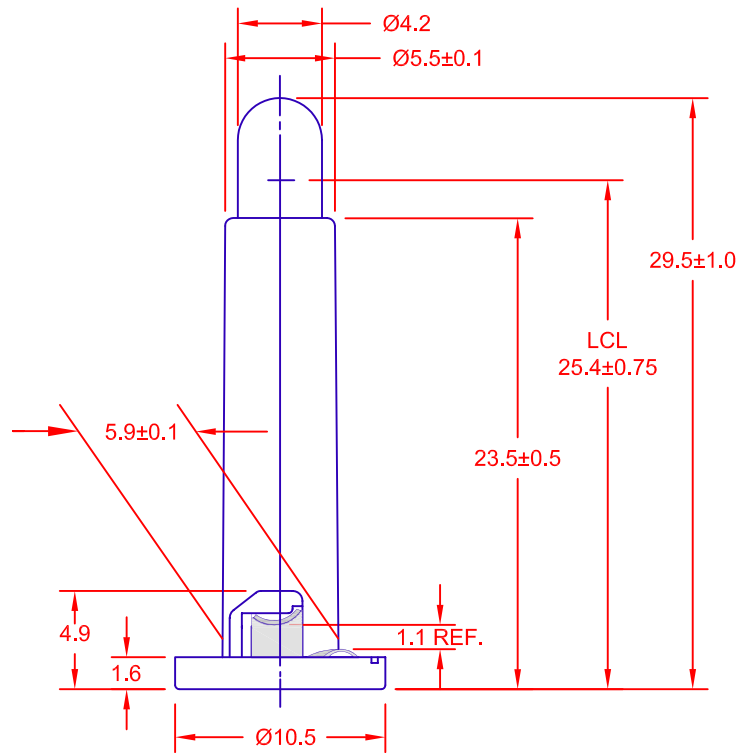

JKL PART NUMBER: DNW21-DW07/GRA/32.5MM***

LAMP NUMBER: DW07**

VOLTS RATED	AMPS ± 10%	*MSCP ± 25%	*LUMENS ± 25%	AVERAGE LIFE HRS.	FILAMENT TYPE
14.0	.080	.300	3.77	7,500 D.C.	C-2F

*LAMP RATING ONLY WITHOUT BASE

**LAMP GLASS LEAD (Pb) FREE

***LAMP AND BASE ASSEMBLY LEAD (Pb) FREE

CONTACT JKL FOR LEAD (Pb) FREE LOT IDENTIFICATION

BASE COLOR

GRAY

METRIC		DIMENSIONS ARE IN MILLIMETERS		JKL COMPONENTS CORPORATION			
 THIRD ANGLE PROJECTION	TOLERANCE UNLESS OTHERWISE SPECIFIED		TITLE T-1 1/4 DOUBLE CONTACT NEO-WEDGE BASE WITH DW07 LAMP				
	1 PL +/- 0.2	2 PL +/- 0.20	ANGLE +/- 0	SIZE A	FSCM NO. 55335	DRAWING NO. DNW21-DW07/GRA/32.5MM	
DRAWN BY L. WENGSTROM	APP'VD BY J.K.	DATE 1/18/05	SCALE NONE	RELEASED DATE 7/15/02	REVISION DATE 1/18/05	REV. NO. A	SHEET 1 OF 1
- CAD DRAWING - MANUAL REVISIONS NOT PERMITTED							