

REV.	DESCRIPTION/ECO NO.	DATE
	RELEASED AND CANCEL P-0104-09	10/17/01
A	DIM CHANGE & ADD BASE COLOR	10/30/01
B	CHANGE TO (Pb) FREE ASSEMBLY	2/24/05

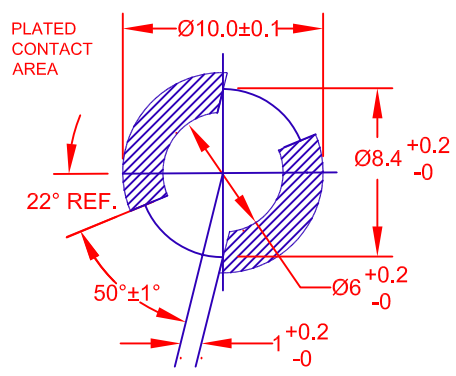
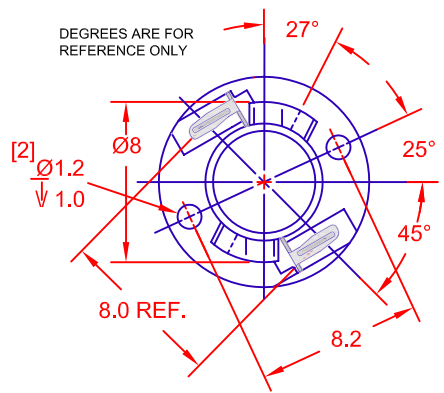

P.C. BOARD THICKNESS 1.6±0.1MM

JKL PART NUMBER: DNW21-EW89/GRA/32.5MM/39-08-5H***

LAMP NUMBER: EW89S**					
VOLTS RATED	AMPS ± 10%	*MSCP ± 25%	*LUMENS ± 25%	AVERAGE LIFE HRS.	FILAMENT TYPE
14.0	.140	.88	11.00	7,000	C-2F

* LAMP RATING ONLY WITHOUT BASE AND FILTER.
 ** LAMP GLASS LEAD (Pb) FREE.
 *** LAMP AND BASE ASSEMBLY LEAD (Pb) FREE.

CONTACT JKL FOR LEAD (Pb) FREE LOT IDENTIFICATION.

FILTER PART NUMBER: 39-08-5H	
COLOR COORDINATES	
x = .3027 ± .025	y = .3805 ± .025

BASE COLOR: GRAY

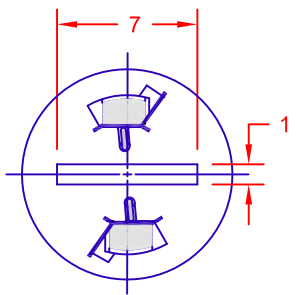
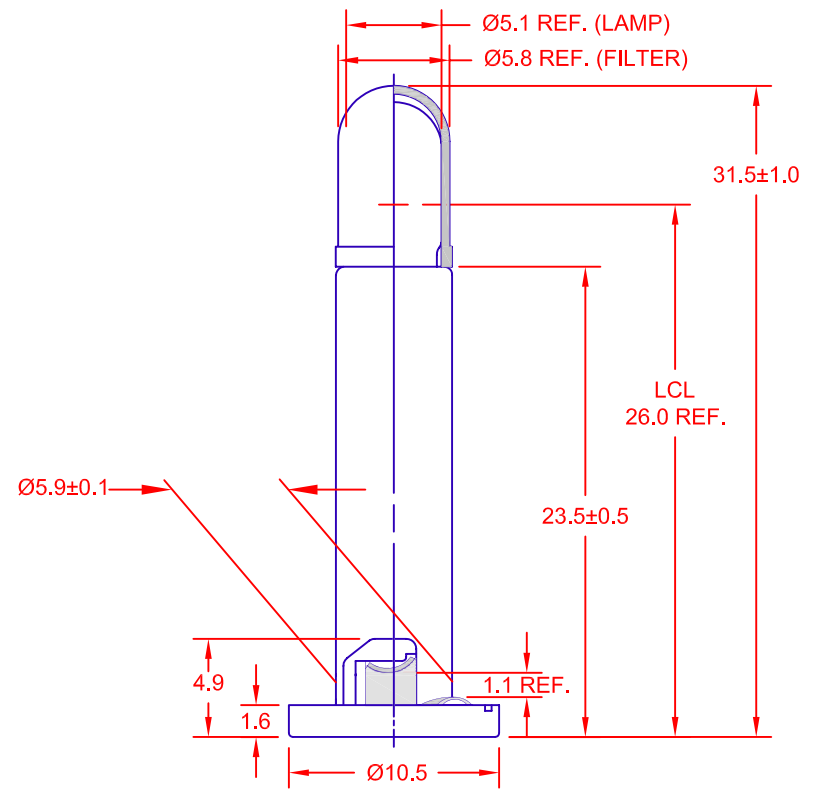

<p>METRIC THIRD ANGLE PROJECTION</p>	DIMENSIONS ARE IN MILLIMETERS TOLERANCE UNLESS OTHERWISE SPECIFIED 1 PL +/- 0.2 2 PL +/- 0.20 ANGLE +/- 0	<h1>JKL COMPONENTS CORPORATION</h1>			
		TITLE T-1 1/4 DOUBLE CONTACT NEO-WEDGE BASE WITH EW89S LAMP AND FILTER			
DRAWN BY L. WENGSTROM	APPV'D BY J.K.	DATE 2/24/05	SIZE A	FSCM NO. 55335	DRAWING NO. DNW21-EW89/GRA/32.5MM/39-08-5H
- CAD DRAWING - MANUAL REVISIONS NOT PERMITTED			SCALE NONE	RELEASED DATE 10/17/01	REVISION DATE 2/24/05
				REV. NO. B	SHEET 1 OF 1